



बैंक नोट पेपर मिल इण्डिया प्रा. लिमिटेड

BANK NOTE PAPER MILL INDIA PVT LIMITED

JV of SPMCIL - A Govt. of India Enterprises & BRBNMPL - A Subsidiary of RBI

email : scmcommon@bnpmindia.com, Ph: 0821 2401 178

ENQUIRY No: BNPM/LTE/Screw Assembly Table/286 /2018-19

Enquiry issuing Date: 10.07.2018
Closing Date: 16.08.2018@ 1000 Hrs
Extended upto:31.10.2018

1. Scope of work:

Supply of **Screw Assembly Table**

2. Terms & Conditions:

S. No.	Particulars	Quantity
1.	Payment Terms	100% on receipt and acceptance of goods by the consignee at destination and on production of all required documents by the supplier. <u>Warranty certificate (if applicable) and NEFT/RTGS details shall be furnished along with invoice.</u>
2.	Price	Price should be inclusive of taxes,
3.	Freight	Shall be included in quoted price
4.	Packing & Forwarding	Shall be included in quoted price
5.	Delivery Terms	DAP, Bank Note Paper Mill India Private Limited, Mysore
6.	Warranty Period
7.	Warranty Certificate	Applicable / Not Applicable
8.	Delivery Period
9.	Material to be delivered at	Engineering Stores Bank Note Paper Mill India Private Limited Note Mudran Nagar Mysore 570 003
10.	Contact person in Engineering Stores	N. Saideep 0821-2401178 Scmcommon@bnpmindia.com



Price Bid Format:

S. No.	Description	Qty.	UOM	Unit rate	Freight, P&F Charges	GST@	Unit rate including GST & Freight, P&F Charges	Grand total inclusive of GST and Freight, P&F Charges (DAP, BNPM, Mysore)
1.	BIVIS Screen Assembly Table; Load carrying capacity: 4 ton; Front wheel: swivel caster wheel with PU coated; Rear Wheel: Fixed caster wheel with PU coated; Drawing No: BNPM/PP/048/2018-19(attached)	01	Nos					
Total price inclusive of all tax, freight , P&F charges								

Note:

1. Attached drawing is as per reference only.
2. Vendor has to visit BNPM site for actual requirement and dimensions
3. Vendor has to submit drawing for approval before start of manufacturing.

We hereby confirm that

1. We accept all terms & conditions mentioned in the enquiry.
2. Price quoted is inclusive of all taxes, P&F, freight etc. on DAP, BNPM, Mysore basis.
3. HSN Code:

Signature of bidder:.....

Name of the Firm:.....

Seal of the firm:

GST No:



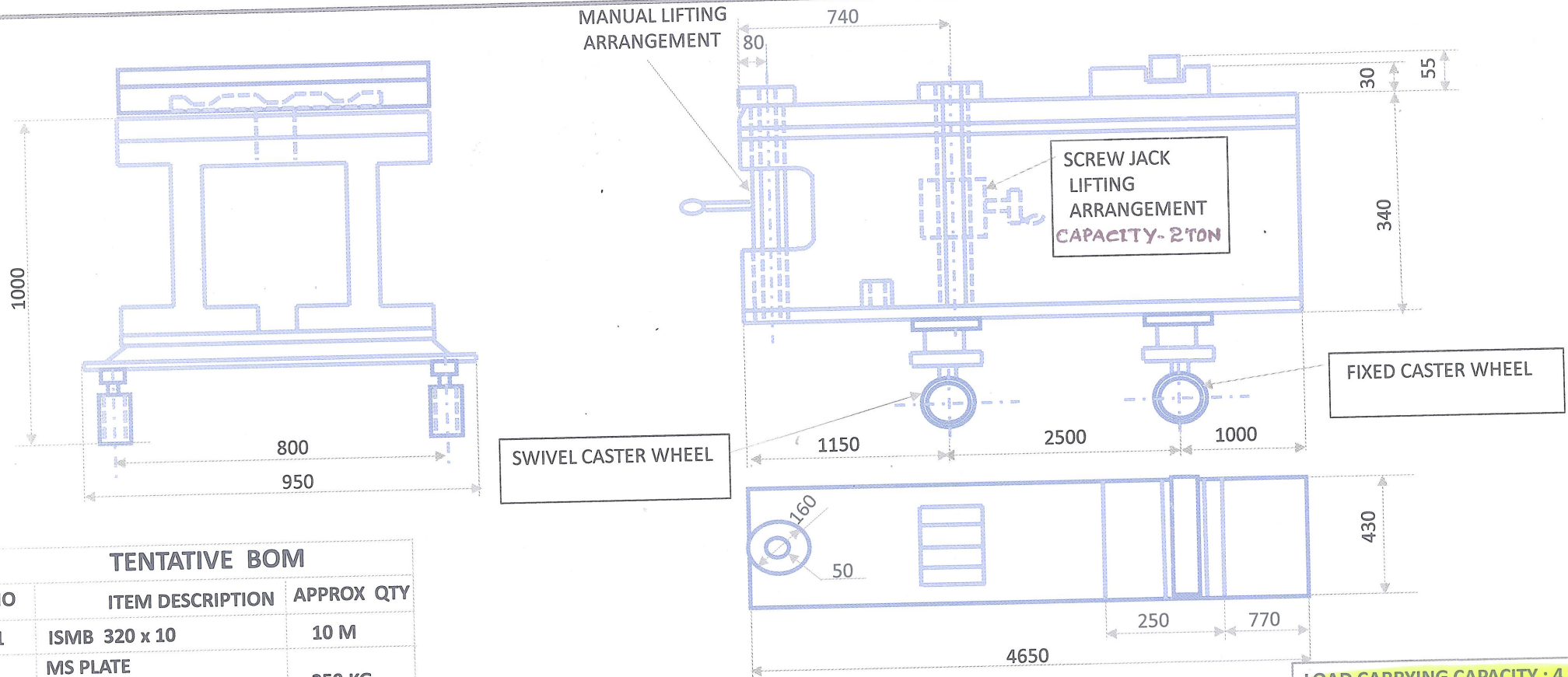

LOAD CARRYING CAPACITY : 4 TON

ALL DIMENSIONS ARE IN MM

TENTATIVE BOM

S.NO	ITEM DESCRIPTION	APPROX QTY
1	ISMB 320 x 10	10 M
2	MS PLATE 10 MM THICKNESS	250 KG
3	SCREW JACK LIFTING ARRANGEMENT	01 NO
4	MANUAL LIFTING ARRANGEMENT	01 NO
5	CASTER WHEEL WITH PU COATING (SWIVEL)	02 NO
6	CASTER WHEEL WITH PU COATING (FIXED)	02 NO

 BANK NOTE PAPER MILL INDIA PRIVATE LIMITED MYSORE-570003		BIVIS SCREW ASSEMBLY TABLE DRG.NO:BNPM/PP/048/2018-19	
PREPARED BY	SIGNATURE		DATE
CHECKED BY			
APPROVED BY			